

ExPolar Heating System

for use with Max actuators and Cos/Bin/Reg sensors
in extreme temperatures to $-50\text{ }^{\circ}\text{C}$

ATEX certified in acc. with directive 2014/34/EU for use in zones 1, 2, 21 and 22

ExPolar - ... - MS

ExPolar - ... - MM

ExPolar - ... - CBR

ExPolar - ... - CT

Subject to change!

Compact. Easy installation. Universal. Cost effective. Safe.

Type	suitable for	Operating temperature to	Supply voltage			
ExPolar- ... - MS	...Max... size S	$-50\text{ }^{\circ}\text{C}$	24 V AC/DC	48 V AC/DC	120 V AC	240 V AC
ExPolar- ... - MM	...Max... size M	$-50\text{ }^{\circ}\text{C}$	24 V AC/DC	48 V AC/DC	120 V AC	240 V AC
ExPolar- ... - CBR*	...Cos..., ...Bin..., ...Reg..**	$-40\text{ }^{\circ}\text{C}$	24 V AC/DC	48 V AC/DC	120 V AC	240 V AC

↑ Supply voltage

ExPolar- ... - CT Types as above in seawater resistant version, terminal boxes with seawater resistant coating (cable glands brass nickel-plated)

* Please see information on ordering, commissioning and the operation of the ...Polar...-CBR with the Cos, Bin or Reg sensors!

** With aluminium housing.

Product images and applications



ExPolar-...-MS



ExPolar-...-MM

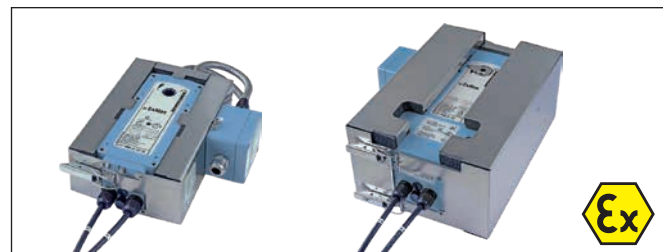

ExPolar-...-MS-CT

ExPolar-...-MM-CT

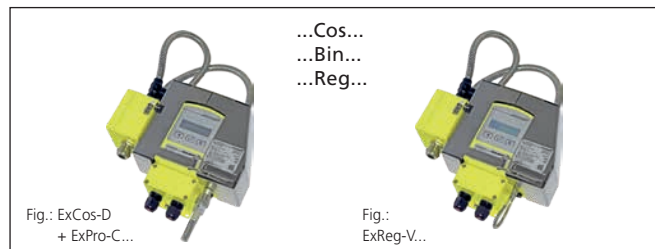

ExPolar-...-CBR

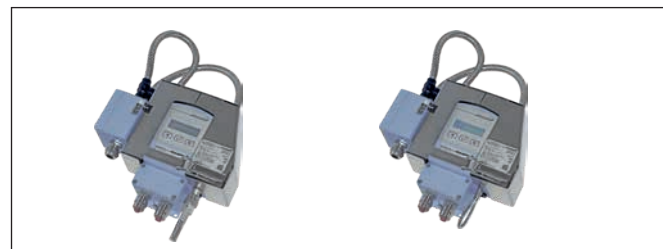

ExPolar-...-CBR-CT

Description

The ExPolar supplementary heaters ensure that Schischek Max actuators can additionally be used at operating temperatures to $-50\text{ }^{\circ}\text{C}$ and Cos/Bin/Reg sensors can be operated to $-40\text{ }^{\circ}\text{C}$ in Ex-area zones 1 and 2 (gases) and 21 and 22 (dust particles).

Compliance with the most stringent Ex classes and best quality materials, IP protection, small dimensions and low weight guarantee safe operation even under difficult environmental conditions.

The ...Polar provides for equilibrium between ambient temperature, temperature of the heating element and the ideal operating temperature of Schischek devices. The stainless steel housing ensures energy efficiency, storing heat and reducing heat loss to a minimum. This will lower your operating costs and make sure that equipment continues to function when you need it.

The ...Polar is fully assembled for easy, on-site installation.

Highlights

- › For all types of gases, mists, vapours and dusts in zones 1, 2, 21 and 22
- › Control thermostat monitors ambient temperatures and heat levels
- › Robust heating including reversible temperature shutdown (thermostat)
- › Easy to install and dismantle
- › Stainless steel housing, IP66 protection
- › High quality, UV-resistant insulation
- › Can be retrofitted
- › Electrical supply via prefitted terminal box
- › All add-ons can continue to be used (note operating temperatures!)

ExPolar heating system

- 1 Heater with integrated temperature limiters
- 2 Thermostat
- 3 Ex-e Terminal box
- 4 Insulation system with stainless steel enclosure
- 5 Stainless steel safety tubing (protects supply cables)

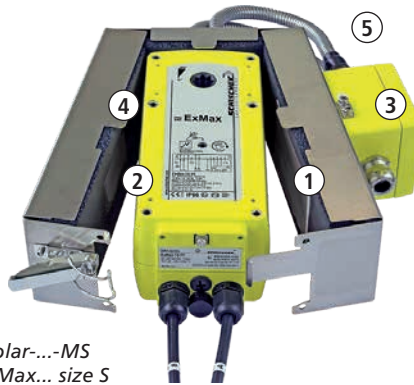

Fig.: ExPolar-...-MS on an ExMax... size S

- | | |
|------------------|----------------|
| ...Polar-...-MS | 1 Heater right |
| ...Polar-...-MM | left |
| ...Polar-...-CBR | left |

Information ...Polar-CBR

Ordering

Please implicitly specify the type of sensor with which you will be using the heating system.

We adapt the housing of the Polar-CBR for the additional output elements of the following sensors.

- Cos with additional analogue outputs: ...Cos-P-...-A, ...Cos-D-A, ...Cos-A-A
- Bin with two and more channels: ...Bin-A2, ...Bin-A5

Types of Cos, Bin, Reg sensors

The Polar-CBR is suitable for Cos, Bin and Reg sensors with aluminium housing.

Please note that equipment with external elements and add-ons that are not heated by the ...Polar... may only be operated and stored at the corresponding specified ambient temperatures!

If you require more information on the operation of equipment with external elements and add-ons, please contact us here at Schischek or get in touch with your local Rotork dealer.

Technical data

Technical data	ExPolar	...-MS	...-MM	...-CBR
Supply voltage/Frequency	24 V AC/DC, 48 V AC/DC, 120 V AC or 240 V AC – 50/60 Hz with AC			
Power consumption	at 24 V: 2.5 A Protection class III (grounded) at 48 V: 1.3 A Protection class I (grounded) at 120 V: 0.5 A Protection class I (grounded) at 240 V: 0.3 A Protection class I (grounded)			
Output (nominal)	60 W ± 5 %			
Electrical connection	Ex-e terminal box with terminals 0.5...4 mm ² , equipotential bonding 4 mm ²			
Cable gland	M20 × 1.5 mm, cable bushing Ø 6...13 mm			
Material Enclosure	Stainless steel No. 1.4404 / UNS-S31603 / AISI 316L			
Heater/Thermostat	Aluminium, seawater resistant galvanised, NBR gasket			
Terminal box	Aluminium, powder-coated, EPDM gasket			
Insulation	Armacell/HT			
Dimensions	see section "Installation"			
Weight		~ 1.9 kg	~ 2.2 kg	~ 1.8 kg
Ambient temperatures	Storage temperature –50...+60 °C, ambient temperature during operation –50...+60 °C			
Humidity	0...90 % RH, non condensing			
Preheat time	~ 1 h			
Thermostat	Heating function: ON / OFF: T _R = –10 °C / 0 °C			
Heating	Temperature monitoring: ON / OFF: T _{1lim} = +60 °C / +15 °C, T _{2lim} = +70 °C / +5 °C			
Operating mode	100 % ED (= duty cycle)			
Scope of delivery	Heating system with insulation, including heating element, control thermostat, terminal box and securing elements			
Status on delivery	Prefitted terminal box	right	left	left

Compliance and certifications

ATEX directive	2014/34/EU	EAC	No. TC RU C-DE.FB08.B.01186
EC type-approved	EPS 13 ATEX 1 560 X	CE identification	CE No. 0158
IECEX certified	IECEX EPS 13.0017X	EMC directive	2014/30/EU
Approval for gas	II 2 G Ex eb mb IIC T6	Low voltage directive	2014/35/EU
Approval for dust	II 2 D Ex tb mb IIIC T80°C	Enclosure protection	IP66 per EN 60529

Important information on installation, operation and maintenance

- All national and international standards, rules and regulations for hazardous Ex-areas must be complied with.
- For electrical installations design, selection and erection, EN/IEC 60079-14 can be used.
- For electrical installations inspection and maintenance, EN/IEC 60079-17 can be used.
- All exposed metal elements, even if these are not live, must be grounded by the protective earthing system irrespective of their rated operational voltage.
- An at least 4 mm² cable must be used for grounding/earthing (potential bonding); this must be in contact with the operating element.
- An annual function test is recommended. See section "Function of the heating system".
- The ambient temperatures for devices, including all non-heated elements and add-ons, may not exceed or fall short of specified ranges.
- If devices, elements and add-ons are operated or stored at ambient temperatures outside specified ranges, these can be damaged and their functioning and safety may be impaired. Devices must be inspected by manufacturers prior to use.
- Close all openings to ensure enclosure protection.
- Clean using a moist cloth only. Remove any accumulated dust.

Ex area –
zone 1, 2, 21, 22



Safe area

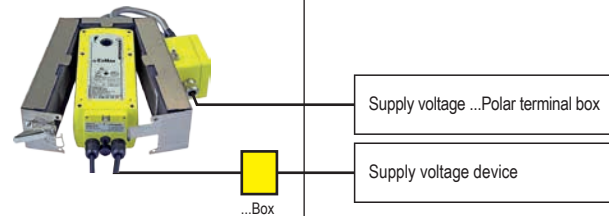

Electrical connection

The supply cable must be securely installed and protected against damage. The operator must ensure that the cable is not exposed to excessive strain. An appropriate fuse must be provided for the power supply.

- Before opening the terminal box, ensure the device is not live.
- Connect power cable to terminal box connectors 1 and 2.
- Connect equipotential bonding cable.
- Operate the ...Polar... only in connection with an actuator or sensor. See section "Commissioning".

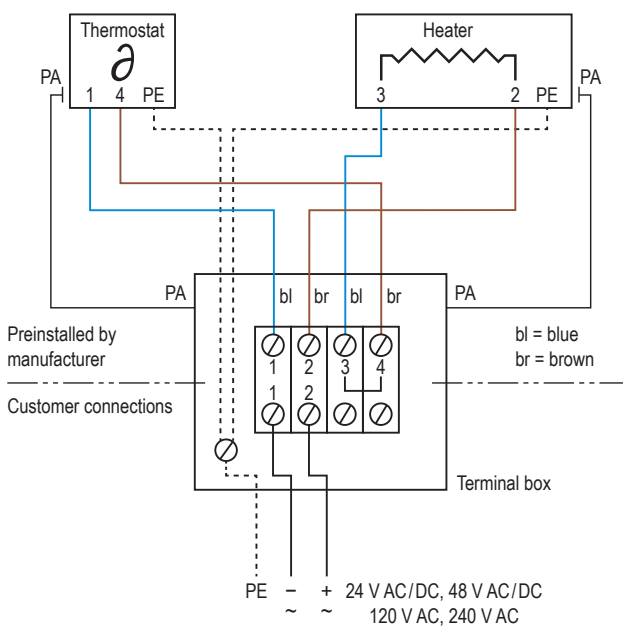

Function of the heating system

Heating

The thermostat T_R controls the ON/OFF switching of the heater during operation.

- If the temperature of the actuator or sensor falls below the lower set threshold of the thermostat, the T_R is activated by closure of the internal contact. The heater is switched ON.
- If the temperature of the actuator or sensor reaches the upper set threshold of the thermostat T_R , the thermostat is automatically deactivated by opening of the internal contact. The heater is switched OFF.

Temperature monitoring

The heater of the ExPolar is protected against overheating by two integrated temperature limiters T_{1lim} and T_{2lim} .

1. If the internal temperature of the heater reaches the upper set threshold of the temperature limiter T_{1lim} , the heater is switched OFF. Once the heater has cooled to the lower set threshold temperature of temperature limiter T_{1lim} , the heater is again ready for operation.
2. If the internal temperature of the heater reaches the upper set threshold of the temperature limiter T_{2lim} , the heater is switched OFF. Once the heater has cooled to the lower set threshold temperature of temperature limiter T_{2lim} , the heater is again ready for operation.

Switching processes controlled by the temperature monitors

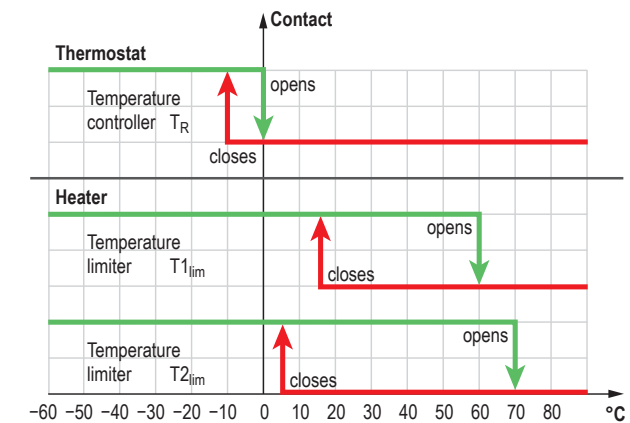

Installation ...Polar-...-M...

The terminal box of the ...Polar-...-M... can be attached to either side of the housing.

Heater and thermostat are covered by foil to protect them during transport. Please ensure that this foil is removed carefully prior to operation!

The housings of actuators are symmetrical along their axis.

You can determine the required direction of rotation during installation. By means of rotation through 180°, the direction of rotation can be adjusted to left or right (left/right installation).

ExPolar-...-MS

with ...Max actuator size S

Upper side
...Polar



Lower side
...Polar



The ...Polar-...-MS can be attached to the actuator prior to or after its mounting on the armature.

The extended brackets on the upper side of the ...Polar housing are used to fix the actuator to the heating system.

1. Mount the ...Polar terminal box if necessary to the opposite side of the ...Polar housing.
2. Determine the direction of rotation required for your application.
3. Remove the protective foils carefully from the thermal pads of the heater and thermostat.
4. Pull the sides of the housing of the ...Polar slightly apart and place the ...Polar over the actuator.
5. Close the spring lock of the housing and secure this with a safety splint. You can also fix the ...Polar to the actuator using securing screws on the lock side.

ExPolar-...-MM

with ...Max actuator size M

Upper side
...Polar

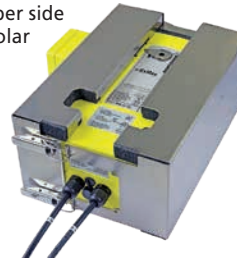

Lower side
...Polar



First attach the actuator to your application so that it provides the required direction of rotation.

Then fix the ...Polar-...-MM to the actuator.

The upper side of the ...Polar housing holds the actuator in contact with the heater.

1. Mount the ...Polar terminal box if necessary to the opposite side of the ...Polar housing.
2. Determine the direction of rotation required for your application.
3. Attach the actuator to your application.
4. Remove the protective foils carefully from the thermal pads of the heater and thermostat.
5. Pull the sides of the housing of the ...Polar slightly apart and place the ...Polar over the actuator.
6. Close the spring locks of the housing and secure these with safety splints. You can also fix the ...Polar to the actuator using securing screws on the lock side.

Note: Ensure the proper thermal contact between thermostat, heater and device. Otherwise the perfect function cannot be guaranteed.

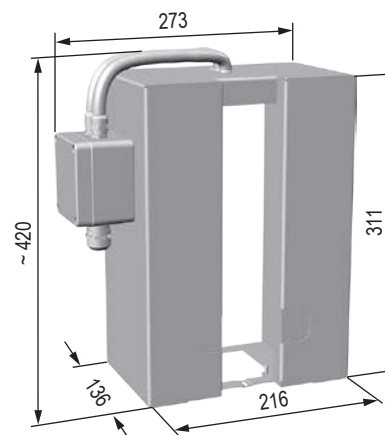
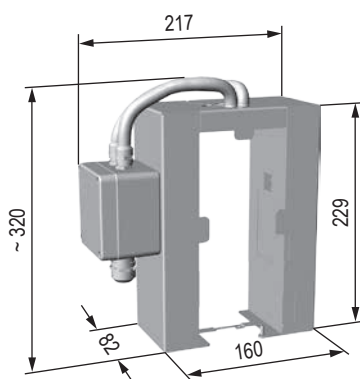

Dimensions in mm
Illustrations similar

Installation ...Polar-...-CBR

Upper side (front side)
...Polar



Fig.: ExCos-D
+ ExPro-C...

1. Attach the sensor to your application.
2. Remove the protective foils carefully from the thermal pads of the heater and thermostat.
3. Pull the sides of the housing of the ...Polar slightly apart and place the ...Polar over the sensor.
4. Close the spring lock of the housing and secure this with a safety splint.

Note: Ensure the proper thermal contact between thermostat, heater and device. Otherwise the perfect function cannot be guaranteed.

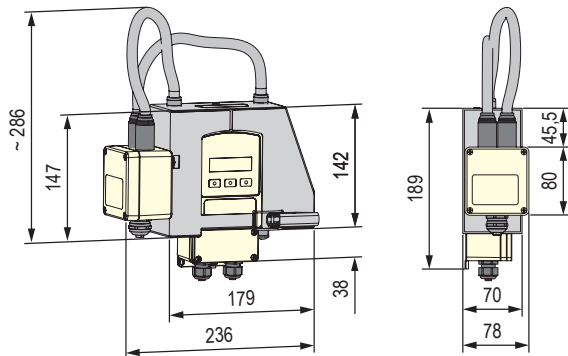

Dimensions in mm

Commissioning

- Operate the ...Polar... only in connection with an actuator or sensor.
- The operating voltage must be applied to the device permanently!

Preheat time

The power supply to the ...Polar must be switched on immediately after attachment to the actuator or sensor. Do not switch on the device during the heat-up phase.

☒ Troubleshooting / Error messages

	Problem	Possible causes	Solution
01	Device does not heat up	• There is a problem with the power supply.	• The ...Polar... must be supplied with power at the specified voltage.
		• The protective foils on heater and/or thermostat have not been removed prior to installation.	• Remove protective foils carefully.
		• Thermal pads have become detached from the heater and/or thermostat.	• The thermal pads must cover the entire surfaces of the heater and thermostat.
		• The temperature has exceeded 0 °C during transport, storage or operation; the heater has been deactivated.	• Allow thermostat to cool to below -10 °C. This will reset the temperature controller.
		• The internal temperature of the heater has exceeded +60 °C during operation; the heater has been deactivated.	• Allow thermostat to cool to below +15 °C. This will reset the integrated temperature limiter.
02	Operation without attached device	• The internal temperature of the heater has exceeded +70 °C during operation; the heater has been deactivated.	• Allow the heater to cool to below +5 °C. This will reset the integrated temperature limiter.
		• The heating system overheats and the protective mechanisms deactivate the heating system.	• Allow the heater to cool to below +5 °C. This will reset the integrated temperature limiter.

Contact us now
mail@rotork.com
www.rotork.com

rotork®

PUB113-196-00
Issue 01/19