

## M Range Hammer Blow Impact Actuator Chain Wheel Installation Instructions

### Model: Direct Mount

#### Procedure:

1. Remove existing valve handwheel and replace with Adapter Plate (A).  
**IMPORTANT: If a Set Screw is not provided in the existing handwheel retaining nut, such provision should be made to eliminate any possibility of the retaining nut backing off the stem.**
2. Install the Anvil (B) by bolting it securely to the Adapter Plate. Once the Anvil is in place, install the Hammer (C) then the Chain Guide (D) (Chain wheel models only). Complete the assembly by attaching the Set Collar (E).
3. When installing, match the Roll Pins in the Set Collar to the holes drilled in the Anvil. Drive the Roll Pins in the Collar into the matching holes in the Anvil. This step is the same for both chain and handwheel models.

#### Parts:

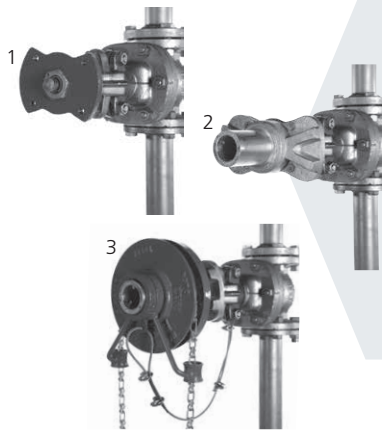
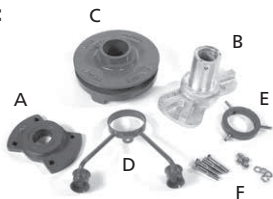

#### Caution:

Chain wheel MUST be installed properly for safe operation. Follow ALL Installation instructions carefully.

NEVER install an M Range Impact Operation on ANY make, model or type of GEAR OPERATED valve.

To eliminate any possibility of the valve handwheel retaining nut backing off the stem, IT MUST HAVE A SET SCREW IN PLACE.

EVERY Impact Operator must be scheduled for REGULAR, PERIODIC inspection and maintenance.

Roto Hammer STRONGLY RECOMMENDS that EVERY overhead Impact Operator be fitted with a Roto Hammer RCK Safety Cable Kit (available from your local distributor or from Rotork).

Set screws and other threaded fasteners MUST be secure and tight.

A. Adapter Plate

B. Anvil

C. Hammer

D. Chain Guide

E. Set Collar with Roll Pins

F. Nuts and Bolts

See other side for Clamp-On installation instructions.

A full listing of the Rotork sales and service network is available on our website.

[www.rotork.com](http://www.rotork.com)

Corporate Headquarters  
Rotork plc

tel +44 (0)1225 733200

email [mail@rotork.com](mailto:mail@rotork.com)

Rotork Controls  
3920 West Point Blvd  
Winston-Salem, NC 27103

tel 336 659-3400

email [US-W5-CS@rotork.com](mailto:US-W5-CS@rotork.com)



Keeping the World Flowing  
for Future Generations

# M Range Hammer Blow Impact Actuator Chain Wheel Installation Instructions

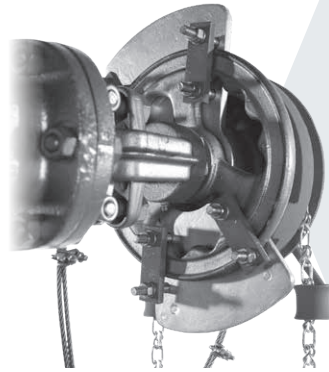

## Model: Clamp-On

### Procedure:

1. Upon opening carton, remove Set Collar (D), Chain Guide (C), and Hammer (B) from Anvil (A).
2. Place Anvil in position on valve wheel with center of Anvil over valve stem. Mark outline of wheel of surface of Anvil.
3. Place clamps (E) on marked surface of Anvil, centering the holes over outline of wheel. Mark and center-punch holes in clamps on the Anvil in the locations shown (Reference Fig. 1). Next, drill Anvil with clearance for bolts. Countersink top side of Anvil for flat head machine bolts.

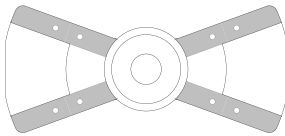

Fig. 1 Location of Drill Holes

4. Bolt Anvil to wheel being careful to center over valve stem.
5. Install Hammer (Chain Guide or Handwheel) and Set Collar. Drive the Set Collar Roll Pins into the matching holes on the Anvil. This assures unit integrity with both a pinning action and friction tightness.

### Caution:

Chain wheel MUST be installed properly for safe operation. Follow ALL Installation instructions carefully. NEVER install an M Range Impact Operation on ANY make, model or type of GEAR OPERATED valve.

To eliminate any possibility of the valve handwheel retaining nut backing off the stem, IT MUST HAVE A SET SCREW IN PLACE.

EVERY Impact Operator must be scheduled for REGULAR, PERIODIC inspection and maintenance.

Roto Hammer STRONGLY RECOMMENDS that EVERY overhead Impact Operator be fitted with a Roto Hammer Retaining Cable (available from your local distributor or from Rotork.)

Set screws and other threaded fasteners MUST be secure and tight.

### Parts:



- A. Anvil
- B. Hammer (Chain wheel model shown)
- C. Chain Guide (Chain wheel model shown)
- D. Set Collar
- E. Clamp Set

See other side for Direct Mount installation instructions.

A full listing of the Rotork sales and service network is available on our website.  
**www.rotork.com**

Corporate Headquarters  
Rotork plc  
tel +44 (0)1225 733200  
email mail@rotork.com

Rotork Controls  
3920 West Point Blvd  
Winston-Salem, NC 27103  
tel 336 659-3400  
email US-W5-CS@rotork.com